

9" KISS Block

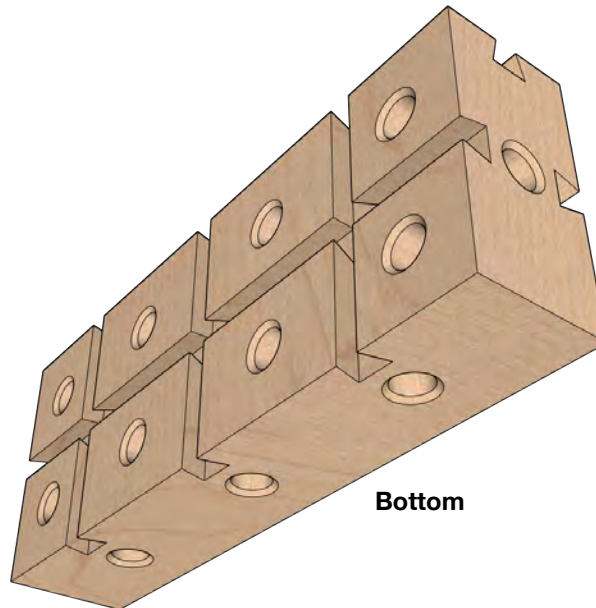

How To Make

9" KISS Block

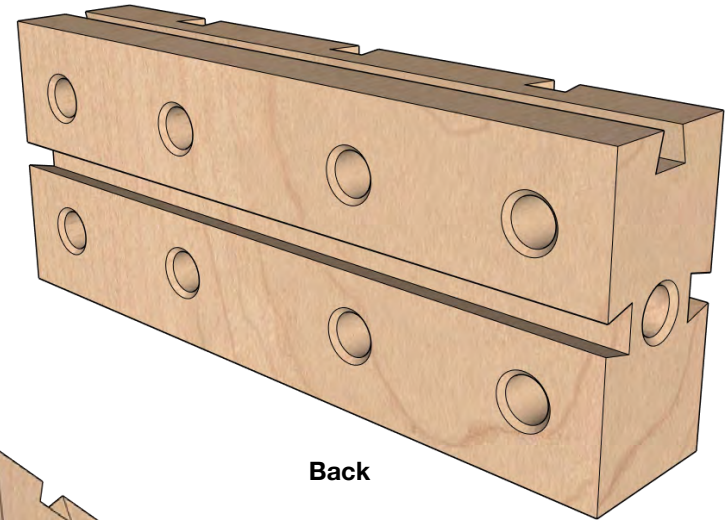
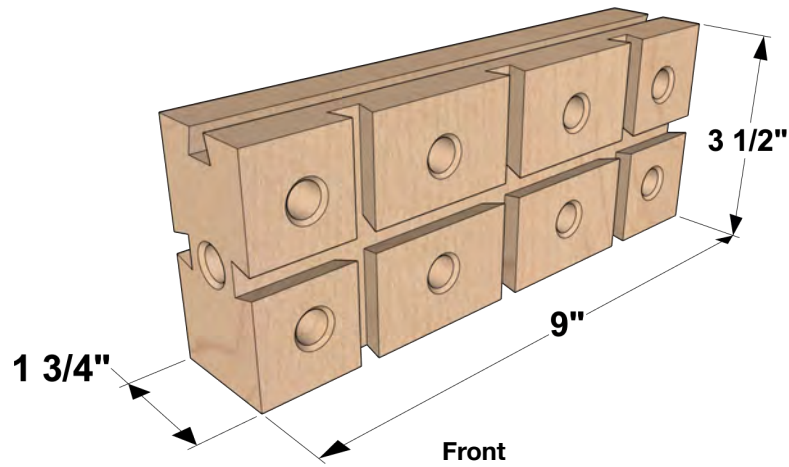
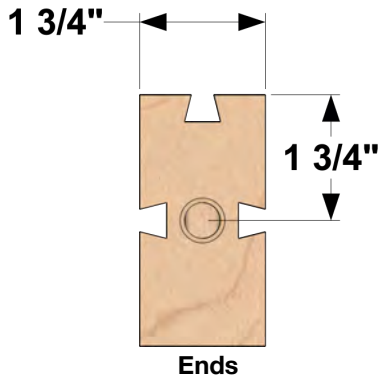
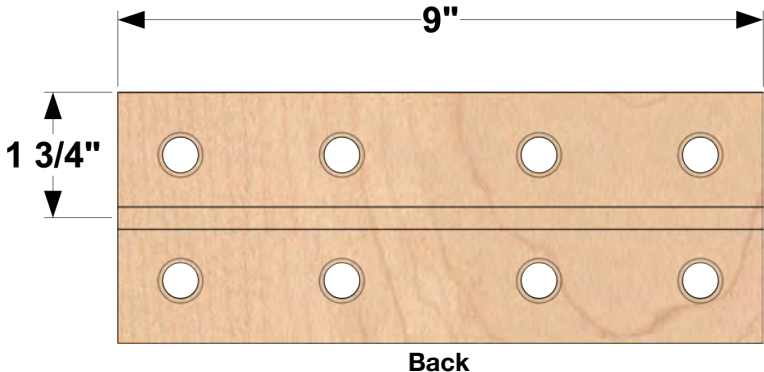
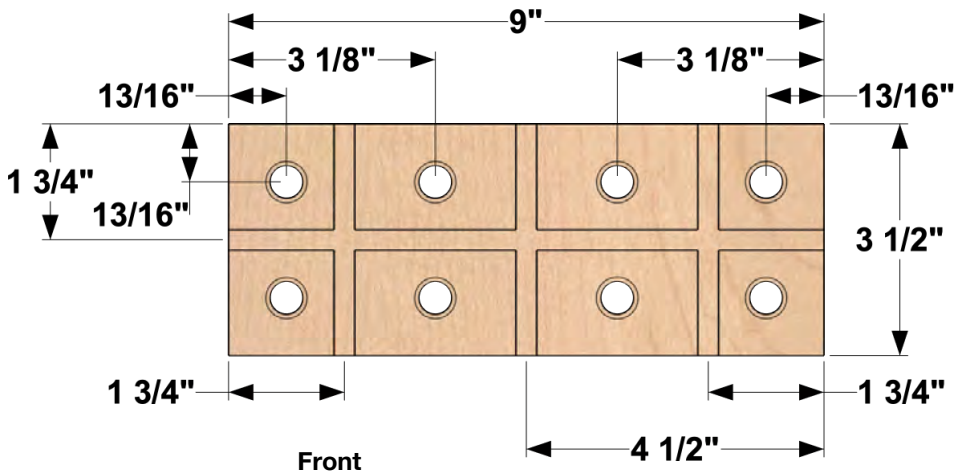

- All grooves are MatchFit and $\frac{3}{8}$ " deep.
- All holes are $\frac{1}{2}$ " and have a slight countersink.
- The holes in the front go all the way through.
- The holes in the ends and bottom are 3" deep.

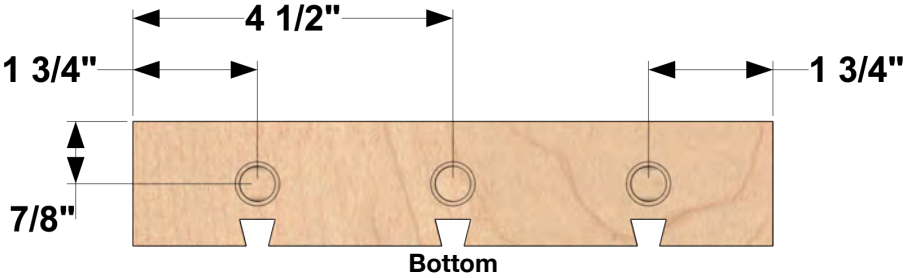
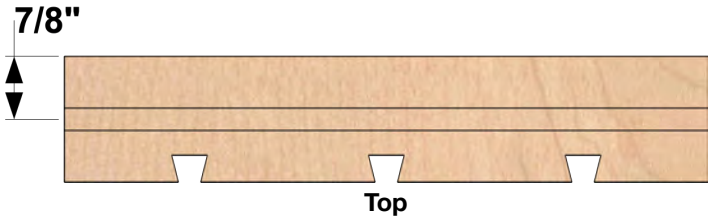

12" KISS Block

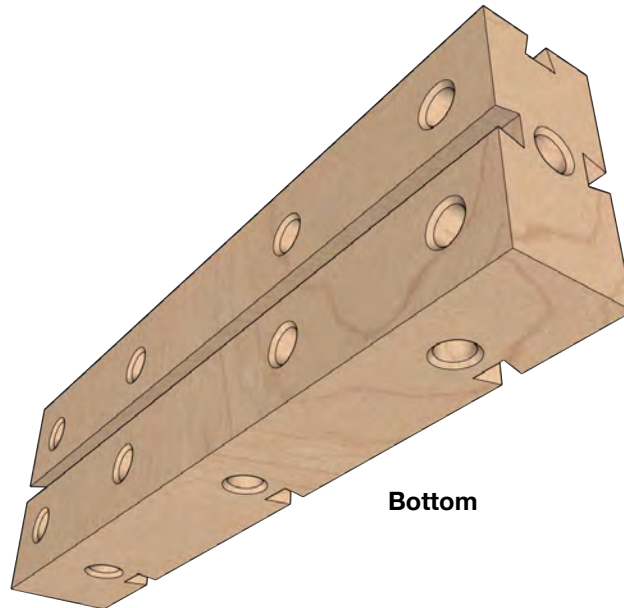
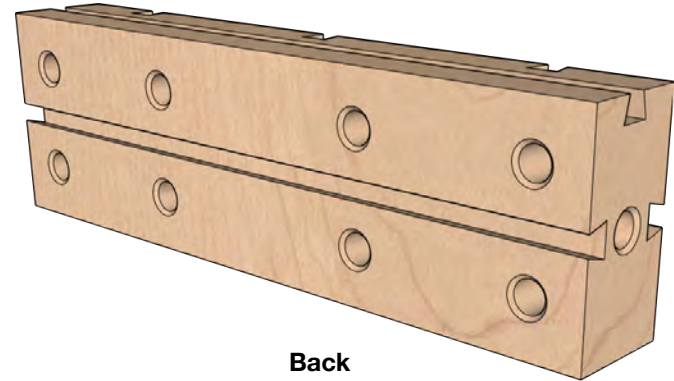
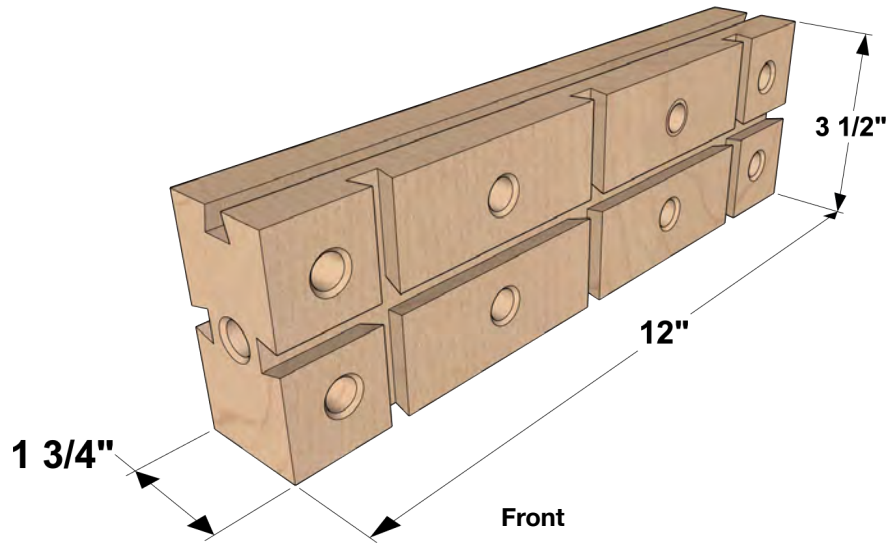

How To Make

12" KISS Block

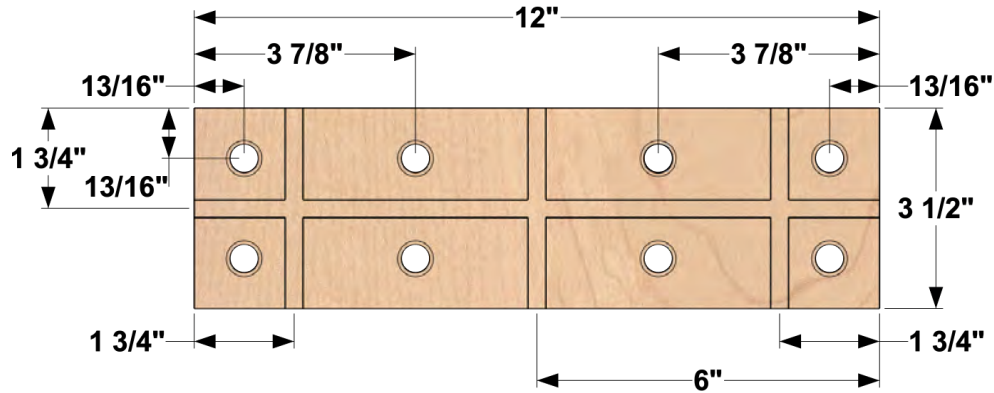

Front

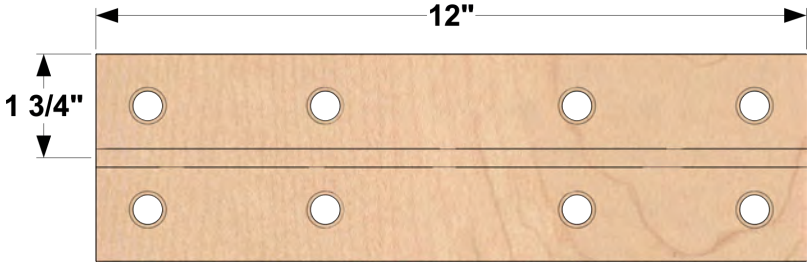

Back

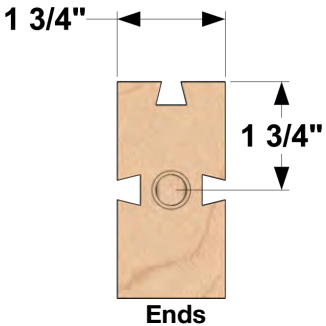

Ends

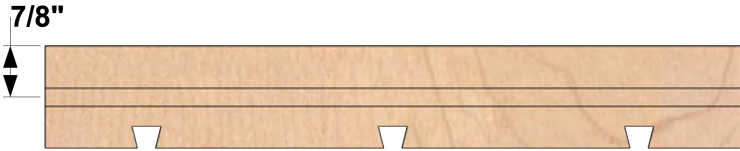

Top

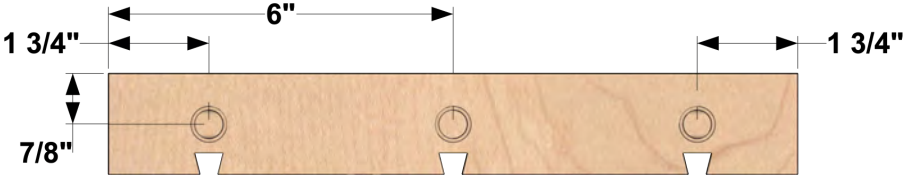

Bottom

- All grooves are MatchFit and $\frac{3}{8}$ " deep.
- All holes are $\frac{1}{2}$ " and have a slight countersink.
- The holes in the front go all the way through.
- The holes in the ends and bottom are 3" deep.



18" KISS Block

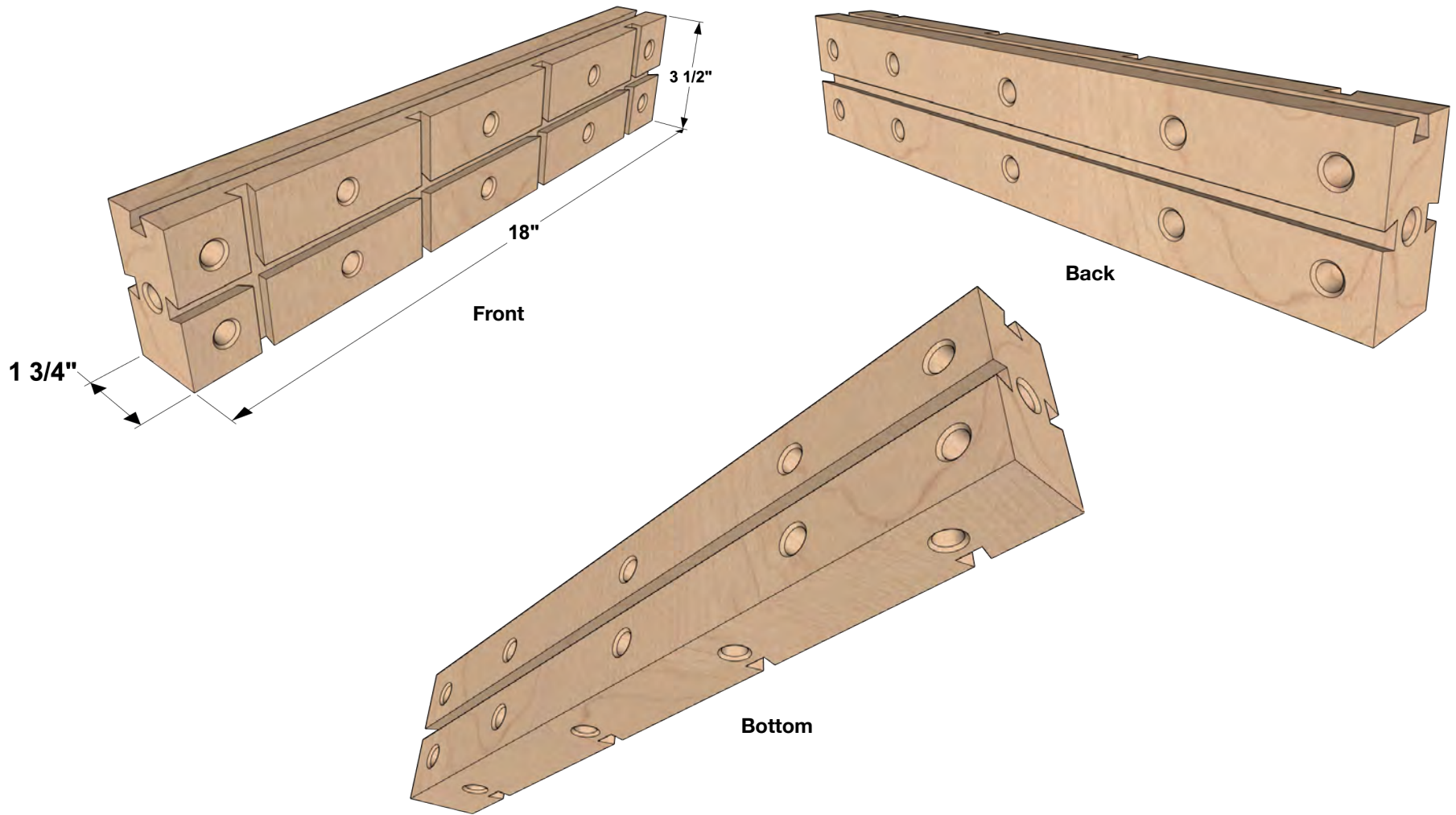

How To Make

18" KISS Block

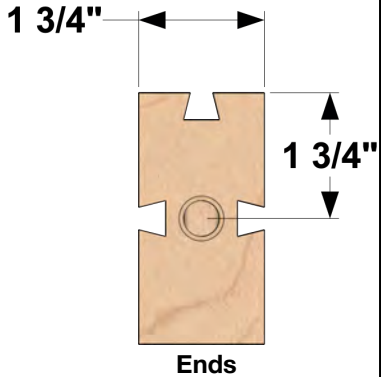
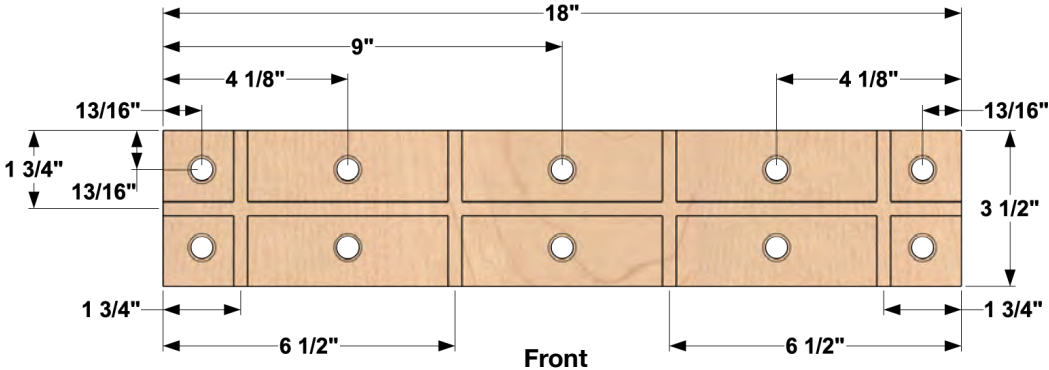

- All grooves are MatchFit and $\frac{3}{8}$ " deep.
- All holes are $\frac{1}{2}$ " and have a slight countersink.
- The holes in the front go all the way through.
- The holes in the ends and bottom are 3" deep.

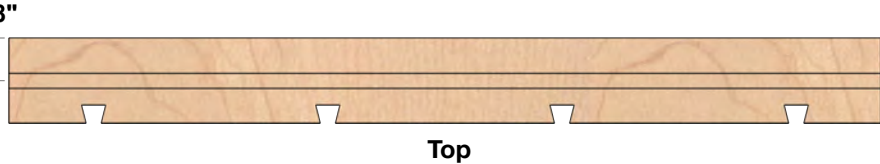
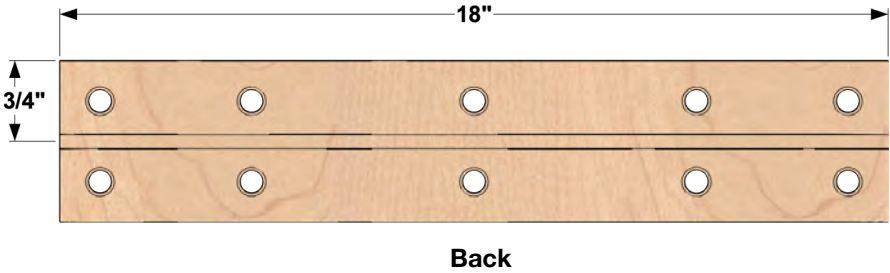



24" KISS Block

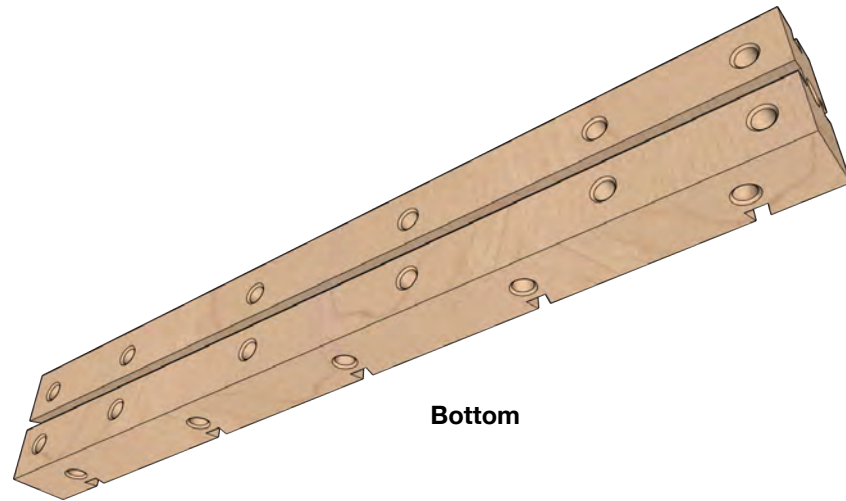
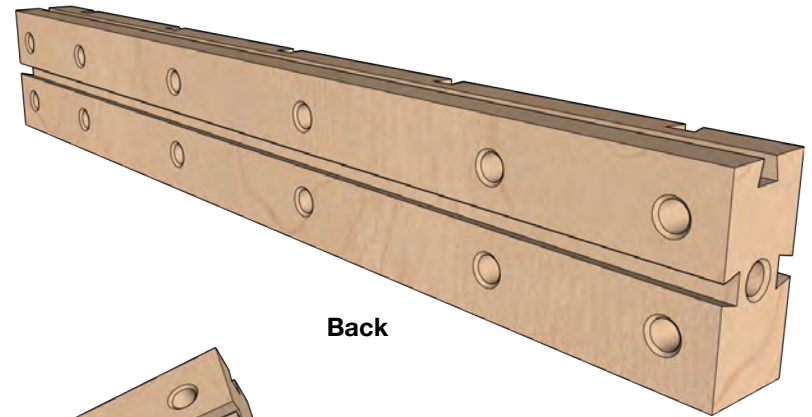
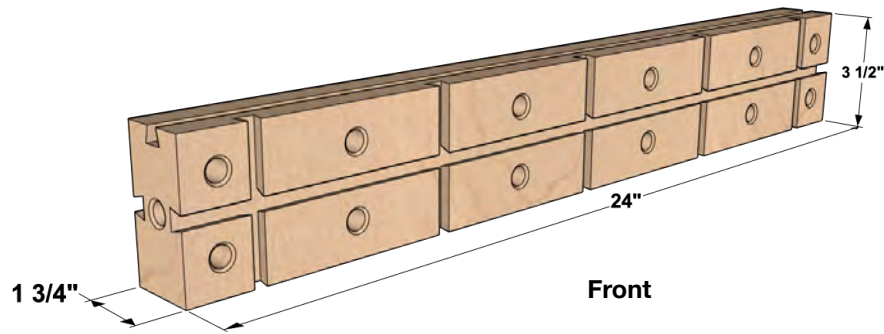

How To Make

24" KISS Block

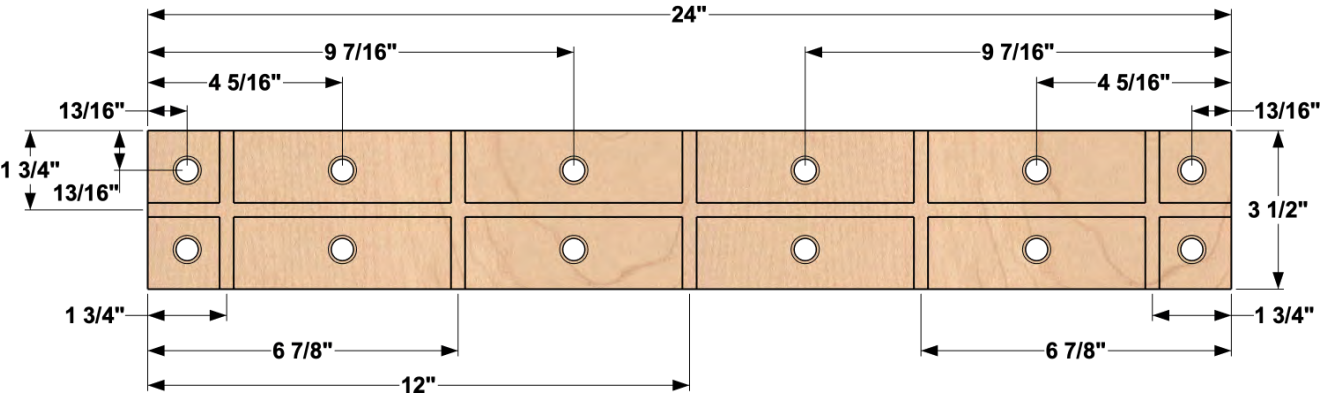

- All grooves are MatchFit and $\frac{3}{8}"$ deep.
- All holes are $\frac{1}{2}"$ and have a slight countersink.
- The holes in the front go all the way through.
- The holes in the ends and bottom are 3" deep.

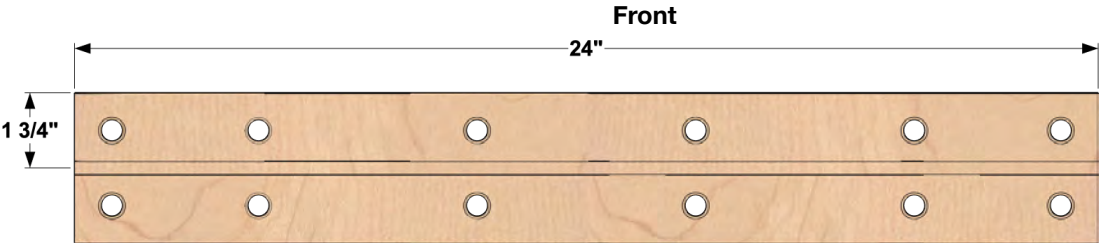

Back

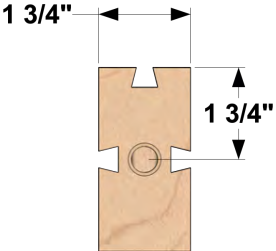

Ends



Top

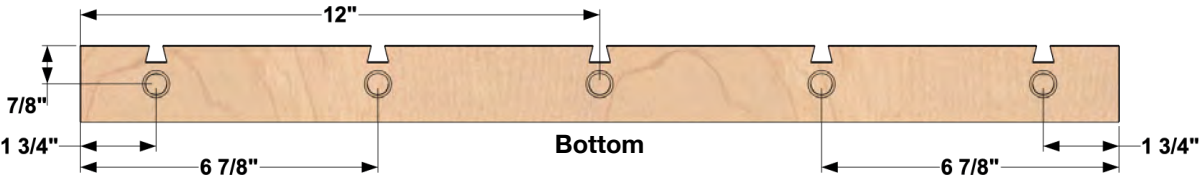

Bottom

