

Coping Saw Construction

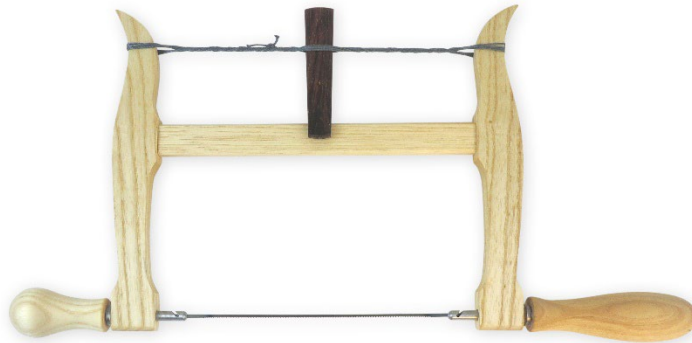

This coping saw kit allows you to make a compact and highly functional saw perfect for cutting tight curves and removing waste between dovetails. It's modeled after classic 18th and 19th century English and American bow saws. While bow saws look surprisingly simple, they work remarkably well and are simple to build. The coping saw frame consists of 3 pieces of wood mortised together to form an "H", (2 upright cheeks and one horizontal stretcher), some simple hardware, 2 turned handles, a piece of twine and a small flat toggle stick. The frame is held together, and the blade tensioned by turning a flat toggle stick, which tensions twine wrapped around the upper portion of the cheeks. This approach allows the thin coping saw blade to be tensioned to a surprising degree. As a result, the highly tensioned blade cuts tight curves with minimal deflection.



Kit Components:

- 1) Two 1/4" stainless steel pins that accept standard pinned coping saw blades. The pins are a 2-piece design and when assembled create a pin with a shoulder and a threaded end that gets glued in the handles.
- 2) 2 Ash handles, one 3-1/2" long and another 2-1/4" long
- 3) One 8' piece of braided fishing line

Specs for Ash saw:

Overall length: 15-1/2"

Height: 8"

Mouth: 4"

Weight: 6-1/2" ounces

Construction:

You can make a saw using one of the 3 plans available [HERE](#), or you can design your own. If you use our plans make the cheeks from 2 pieces of straight grained, defect free, strong hardwood 1/2" thick x 1-1/4" wide and 8-1/2" long. These blanks are slightly oversize as it is much easier to cut accurate profiles with some waste to the outside of your line. Wood choice for the cheeks and stretcher is critical as these parts will be subjected to extreme compressive and bending forces. Choose wood with high bending strength and stiffness. See chart comparing woods [HERE](#). The best domestic hardwood is hickory, but ash, beech, birch, red or white oak and hard maple are also great choices.



Figure 1: Proper grain orientation is critical.

Cheeks

Using one of the provided patterns, transfer the cheek profiles to 2 blanks. To get full size plans you will need to print using Acrobat and select the “Fit to printable area” in the Scale section. If you create your own design, make sure all sections of your cheeks are at least $\frac{1}{2}$ ” wide to keep the wood from splitting. Mark and drill both $\frac{1}{4}$ ” pin holes centered and $\frac{3}{8}$ ” from the bottom edge. Using a drill press with a fence is the most accurate way to get the holes straight and centered.



Figure 2: Drilling pin holes

Mark out and create the $\frac{1}{4}$ ” wide x $\frac{1}{2}$ ” long x $\frac{7}{16}$ ” deep mortises in the cheeks. You can use a router, mortiser or cut by hand with a chisel. One simple approach is to drill two $\frac{1}{4}$ ” holes $\frac{1}{4}$ ” apart using the same drill press set up used to drill the pin holes, and then clean out the waste with a sharp chisel.



Figure 3: Drilling mortise holes



Figure 4: Using a 1/4" spacer when drilling mortise holes reduces measuring

It is much easier to create mortises in the cheeks while the blanks are still square. Use a scroll saw or bandsaw to cut the profiles and a drum sander or rasp/file to refine the shape and remove any saw marks. You could also make a pattern from 1/4" plywood or MDF, affix this to your blanks with double stick tape and pattern route to create the profiles.



Figure 5: By cutting your blanks 1/4" wide you allow some waste to one side of the profile to aid in band sawing and sanding/rasping to final shape. Make sure to line up the side of the template with the mortise to the edge of the blank.

Ease the square bottom of the cheeks with a 3/16" round over bit. Using the bandsaw or table saw rip the bottom section of the cheeks to final 1" width. While not necessary, tapering the top section of the cheeks can

lighten the saw and improve the overall aesthetic. Taper the top portion of the cheeks with a tapering jig described below. Sand all flat sides and ease the edges. Sanding the flat sides is easily done using a sanding board made by gluing a piece of sandpaper to a piece of plywood.



Figure 6: Ripping bottom of cheeks to 1". For safety, a small handle is attached with double-sided tape



Figure 7: Ripping tapers with custom taper jig. A small quick grip clamp holds cheek in place.

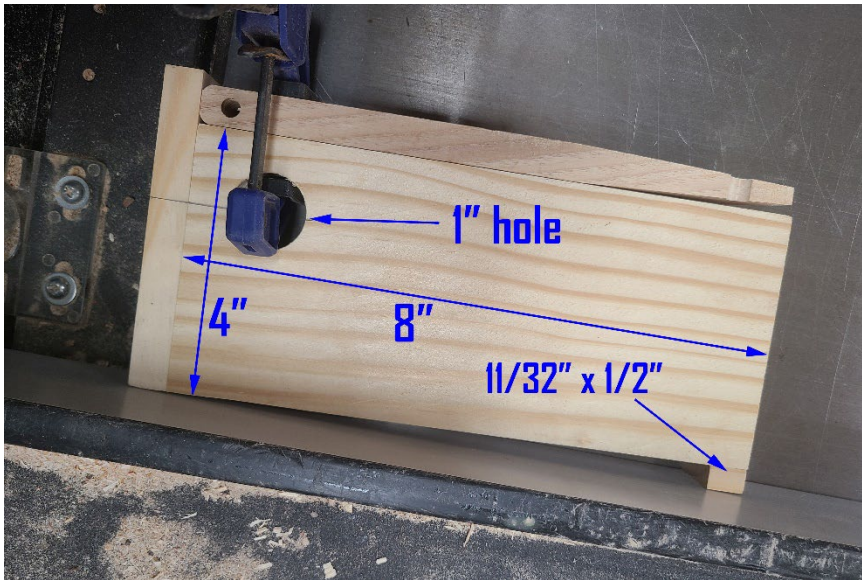

Figure 8: Taper jig dimensions



Figure 9: Sanding board in action

Handles:

The handle hardware assemblies are made up from the large and small turned wood parts, pins, threaded washers, and a leather friction washer (for the large handle only). The leather friction washer helps provide some resistance to handle rotation but still allows easy adjustment. To help further limit handle rotation, scuff sand both washers on 80 grit sandpaper before threading onto the pins. Thread the washers on the pins being careful to place the scuffed side facing the blade slot side of the pins. Glue the threaded portion of the pins in the handle holes with slow setting epoxy. If there is resistance getting the pins fully seated, use a small clamp to bring them home. NEVER pound the pins with a mallet or hammer as you could damage the slotted portion.



Figure 10: Scoffing pin washer on 80X sandpaper



Figure 11: Large handle assembly installed with stainless steel pin, washer and leather friction washer



Figure 12: Fully seating pin in handle with small clamp

Stretcher:

Cut a stretcher $3/4" \times 3/8"$ and slightly longer than needed at 8-10" long. Due to slight variations in coping saw blade size, determine the exact length the stretcher will need to be by measuring directly from the cheeks with the handles and blade installed. Slide the leather friction washer on the large handle pin and insert both handles in the cheek holes (make sure the epoxy is fully cured). Install a coping saw blade, remove any slack between cheeks and measure the inside distance between both cheeks. This measurement is the length of the stretcher shoulder. Add $3/4"$ to this measurement to allow for the $3/8"$ tenons. Now, cut $3/8"$ tenons on both ends. Aim for a tight friction fit so the tenons can be inserted in the mortises but will not fall out on their own. If you left your mortise ends rounded, you will need to round all the outside corners of your tenons.

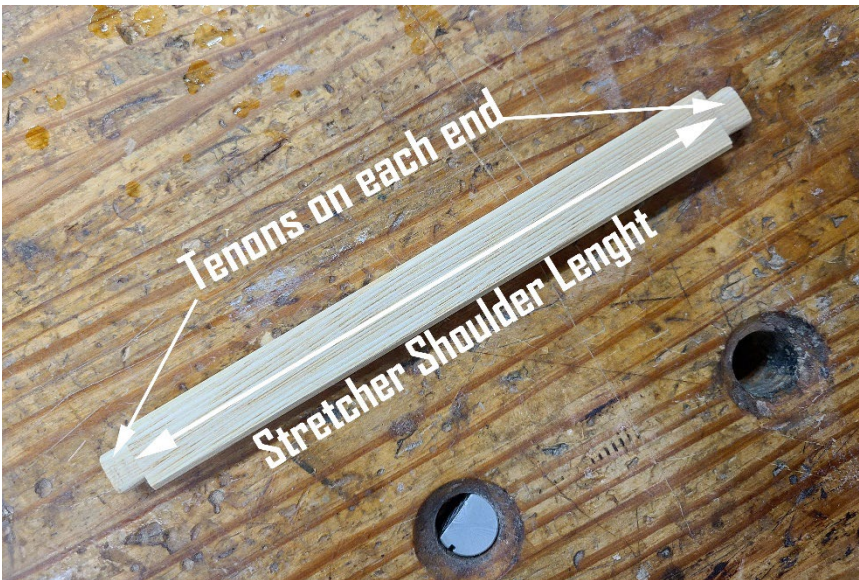

Figure 13: Stretcher shoulder



Figure 14: Sizing stretcher shoulder



Figure 15: Cutting small tenons on the table saw



Figure 16: Rounding tenon corners with curved tooth safe edge file

Finish:

Finish all parts using the finish of your choice.

Assembly:

Slip the leather friction washer over the pin on the larger handle. Push the handle assemblies through the pin holes in both cheeks. Insert the stretcher tenons into the cheek mortises. Install a blade. Loosely wrap the twine around the top portion of the cheek for a full 4 revolutions. This twine is extraordinarily strong and will not stretch, so if you do not leave some slack in the line you may not be able to insert or remove the blade. Tie the ends with a square knot and trim the waste. Slip the toggle stick between the twine and tension the blade by rotating the toggle stick and then place one end against the stretcher to hold the tension. There is no strict formula on how to set the tension except how the saw cuts. Make a few test cuts making same curves. If the blade cuts smoothly without bouncing and minimal blade deflection, the tension is correct. Make sure to take full length strokes, not forcing the cut but allowing the blade to do the work. If you feel more tension is needed but that a full turn of the toggle might be too much, release the tension, remove the toggle stick from between the string, flip it 180 degrees, then place it back between the twine and retention the blade. This allows you to have the wider end of the toggle in the upward position, which is more aesthetic. When not in use it is a good idea to unwind the toggle stick by one turn to release the tension.

Tips for more efficient and precise cutting:

- 1) Use the full length of the blade. This will increase cutting efficiency and greatly prolongs blade life.
- 2) When cutting a curve, make turns during the stroke of a cut as you are cutting, not when the blade is still. This will minimize blade deflection and increase the accuracy of the cut.
- 3) Slow down and let the blade do the cutting. Do not force the cut.
- 4) When using the Bird's Mouth platform (see below), if possible, move the saw only up and down while turning the workpiece on the platform, rather than moving the saw along the line.

Using a Bird's Mouth coping saw cutting platform.

A Bird's Mouth platform is basically a board with a notch and a hole drilled in the center. This simple device helps hold pieces in place when being cut with a coping saw, allowing for more precise cutting. It also allows cutting of thin pieces without fear of breakage. When using a Bird's Mouth platform, the coping saw is set to cut on the pull stroke so gravity can assist with cutting and keeping cuts vertical.

There are 3 types of Bird's Mouth platforms:

- 1) **Height Adjustable:** The height can be adjusted by securing it in any vise. Work can be raised to a more ergonomic height and brought closer to eye level for more precise cutting. Optimal height is between shoulder and chest height.



5" x 8" platform with 3/4" hole drilled in 3-1/2" in from the end. V opening 1-1/2" at widest.



Overall height 24"

- 2) **Table Mounted:** A table mount allows attachment to any work surface with a T track or Matchfit F style clamp. The user must be sitting at the bench to use this platform.



5" x 12" with 3/4" hole drilled 3-1/2" in from the end. V opening 1-1/2" at widest. 3/4" hole drilled 4-1/2" in from opposite end with 3/8" x 5/8" clamp channel milled on top face to house clamp below platform surface.

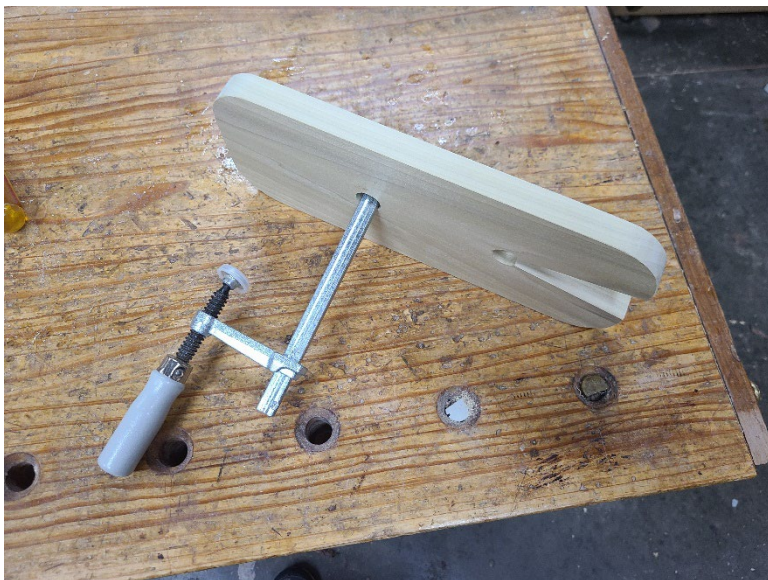

Table mounted platform with clamp in place

- 3) **Vise Mounted:** A vise mount allows securing in a woodworking vise. The user must be sitting at the bench to use this platform.



5" x 10" with 3/4" hole drilled 3-1/2" in from the end. V opening 1-1/2" at widest. Vertical vise mount support leg is 2-1/2" high mounted 2" in from end.



Coping Saw

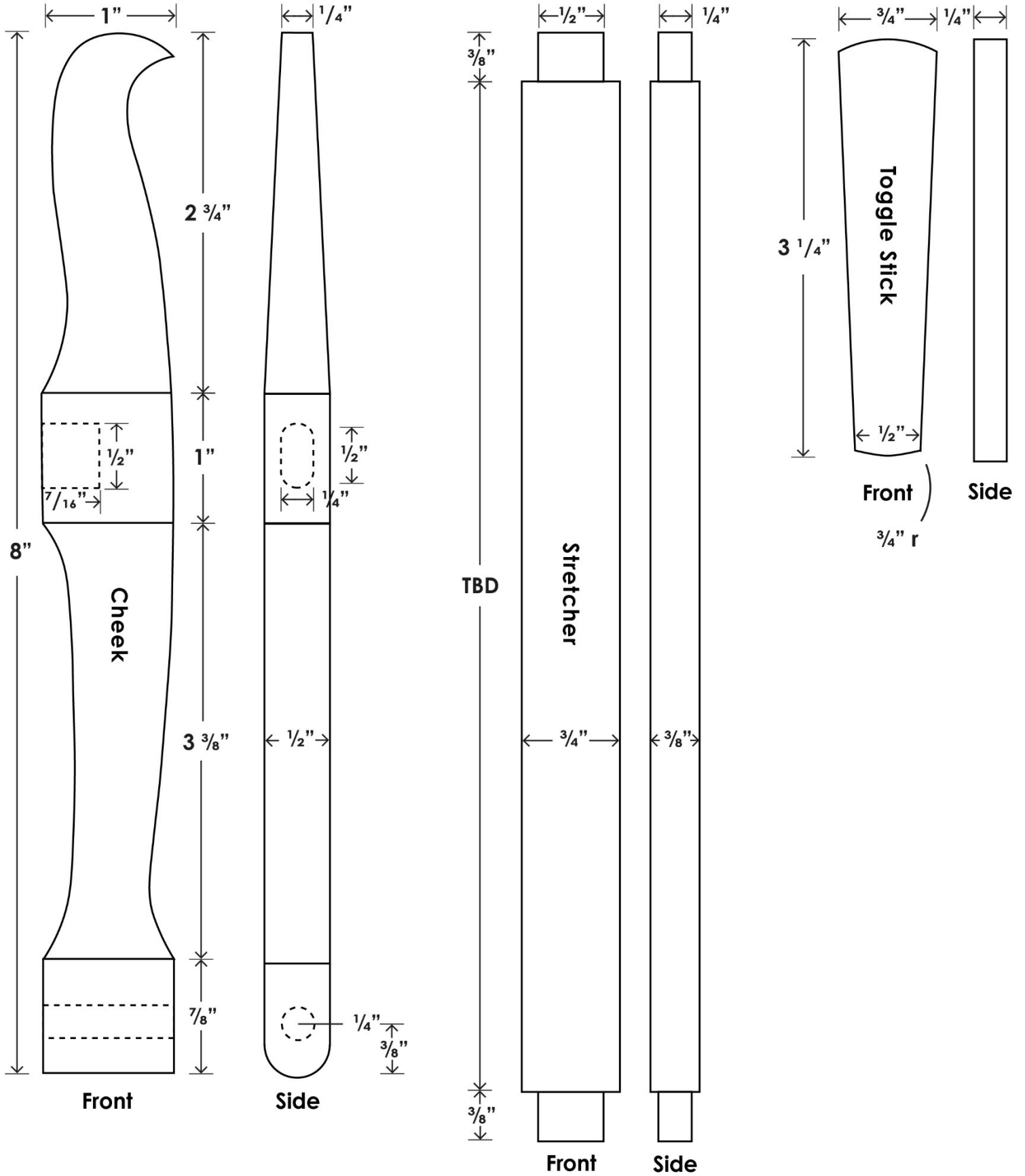

Coping Saw

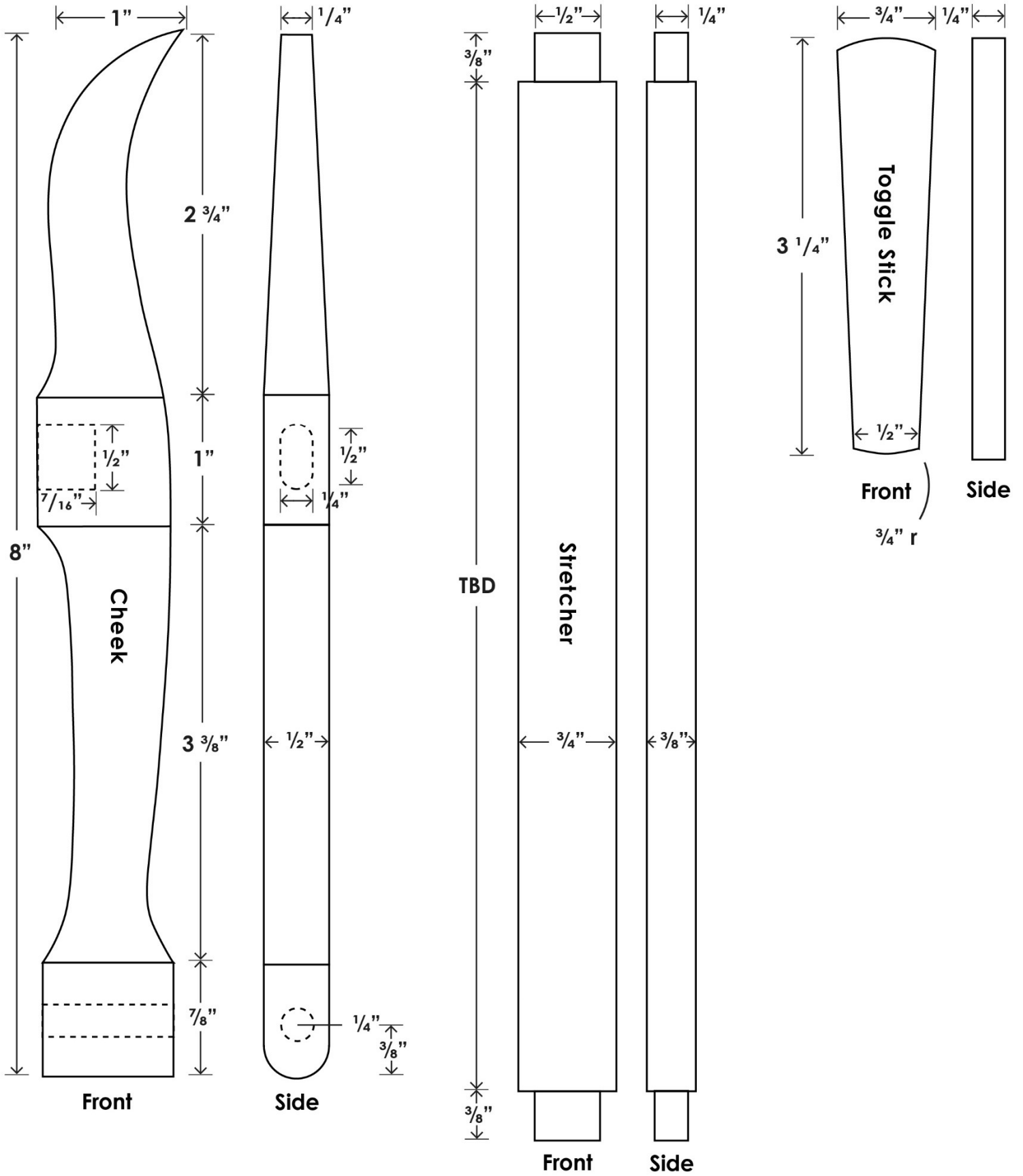

Coping Saw

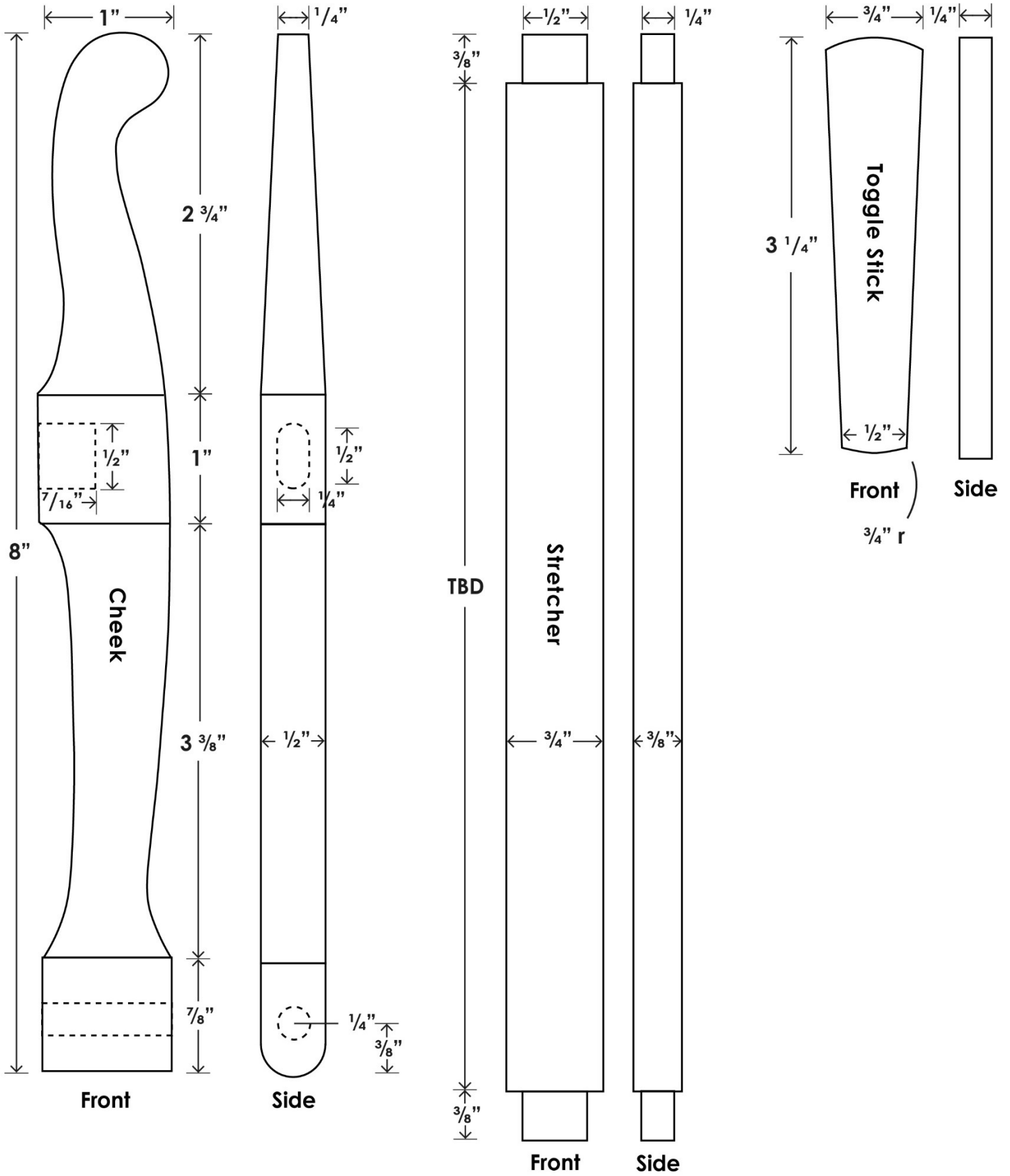

Handles

