

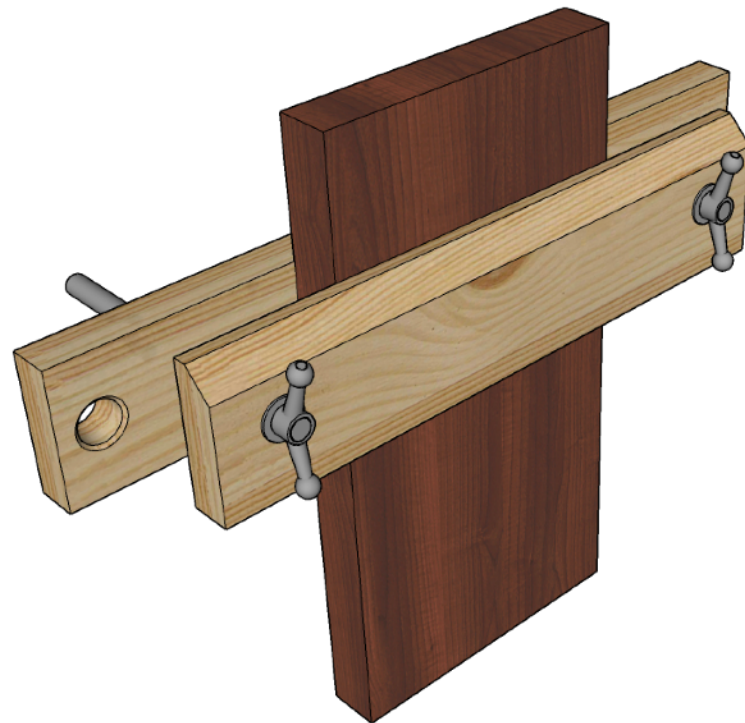

# Improved Moxon Vise



# Introduction

The Moxon Vise, a twin-screw work-holding fixture with a rich history in furniture shops, was first illustrated by Joseph Moxon in his 17th-century book, *The Art of Joinery*. This versatile workbench accessory is remarkably simple and quick to build, offering the ability to stabilize boards with incredible force during various joinery, shaping, or carving operations. It also allows for raising the workpiece to a more comfortable and ergonomic height. Its high portability enables quick mounting on numerous surfaces, and when not in use, it can be stowed away on a shelf or hung on a wall.

In a traditional Moxon Vise, both screws are attached to the rear jaw, held secure by four nuts, with two mortised in the rear jaw flush with the front surface. However, this design leaves both screws protruding from the front jaw, potentially interfering with the user. Our improved Moxon Vise addresses this issue by embedding threads in the rear jaw, allowing both rods to pass through the back jaw as the front jaw is opened and closed, leaving the front unobstructed. Additionally, the screws ride in steel bushings, reducing friction and simplifying construction, as nuts no longer require hand mortising in the rear jaw.

The Moxon Vise hardware kit, despite being economical, includes high-quality 3/4-10 threaded rods, nuts, washers, and cast knobs—everything needed (excluding wood) to create a fully functional Moxon Vise. The plan provides measured drawings and comprehensive instructions for the construction process, but customization options abound. You can tailor it to your preferred width, height, and wood choice, offering a multitude of possibilities for individualization. The details are left for you to decide.

# Cut list & Supplies

Make sure to read through this build guide **BEFORE** cutting any wood. Familiarize yourself with the tools, techniques, and your approach to building this project.

Item	Quantity	Sizes needed
Front Jaw	1 per vise	5 3/8" x 24 x 1 1/2"
Rear Jaw	1 per vise	5" X 30" x 1 1/2"
Rear Square Nut Brackets	2 per vise	2 1/2" x 2 1/2" x 1 1/8"

The wood you choose for the vise is up to you. The Jaws need to be smooth and perfectly flat.

The Moxon Vise Hardware Kit and the recommended Steel Bushings can be purchased from Taylor Toolworks:

[Twin Screw Vise Hardware Kit](#)

[Steel Guide Bushings](#) (3/4" ID x 1" OD x 1-1/4") - although these are not required, they are highly recommended. The vise uses two of these.

# Rear Jaw - if using the 1" Steel Bushings

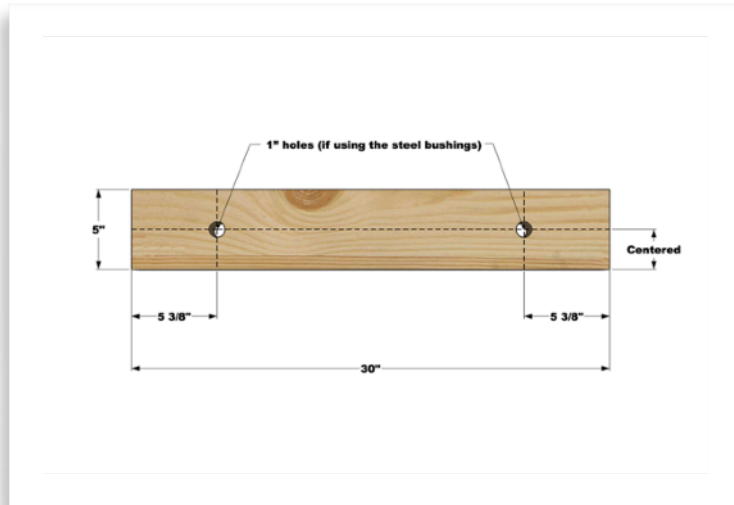

- o Cut one piece 5" x 30" of 1 1/2" thick wood for the Rear Jaw.
- o Drill a 1" hole at 5 3/8" from each end, in the center of the Rear Jaw.
- o Flip the Rear Jaw over.
- o Drive the 1" Steel Bushings into the 1" holes you drilled in Rear Jaw.

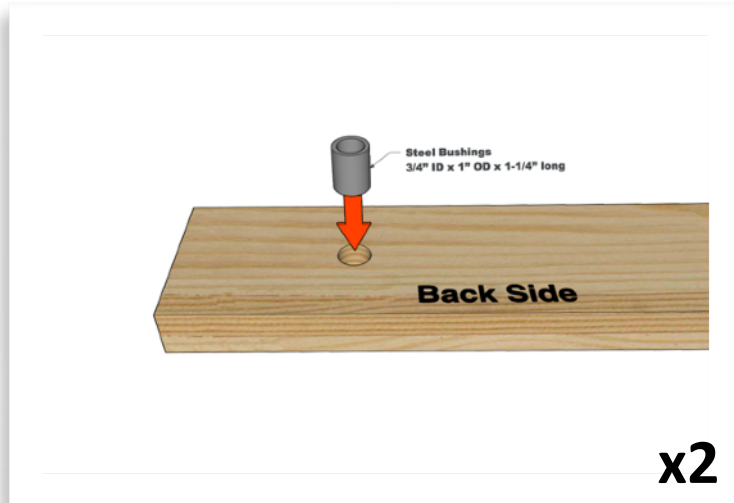

Make sure the end of the Steel Bushings are flush with the face of the Rear Jaw.

# Rear Jaw - if NOT using the Steel Bushings

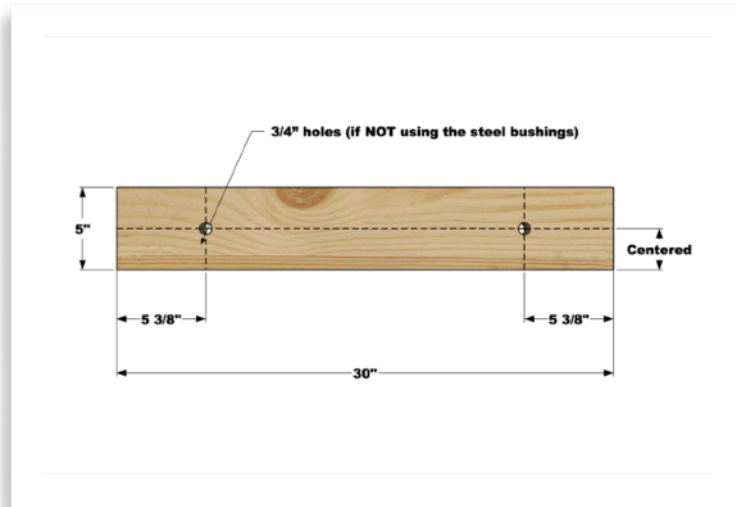

- Cut one piece 5" x 30" of 1 1/2" thick wood for the Rear Jaw.
- Drill a 3/4" hole at 5 3/8" from each end, in the center of the Rear Jaw.

# Rear Jaw (continued)

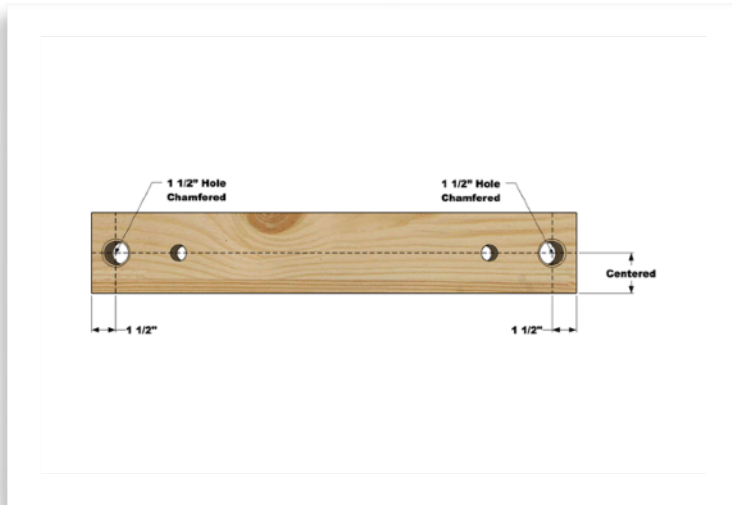

- Drill a 1 1/2" hole at 1 1/2" from each end, in the center of the Rear Jaw.
- Route a shallow chamfer on these two 1 1/2" holes.

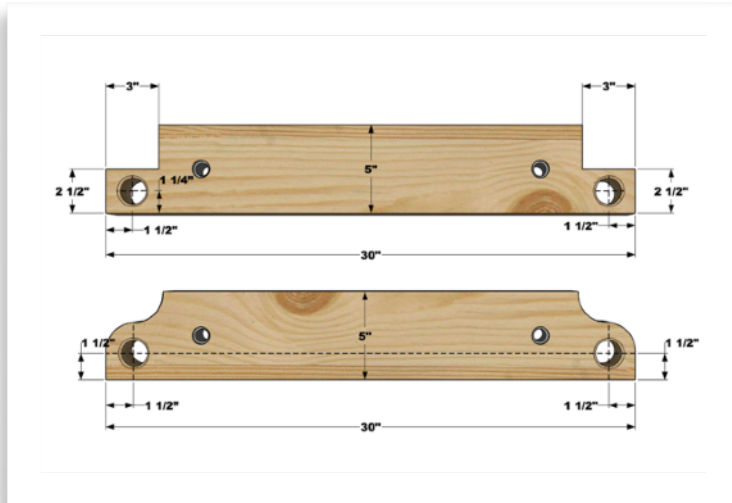

These are alternative designs for the Rear Jaw. It operates the same as the previous layout, this is simply for aesthetic reasons.

The smaller 1" (or 3/4") holes are in the same location.

The larger 1 1/2" holes are in lower positions.

# Square Nut Brackets

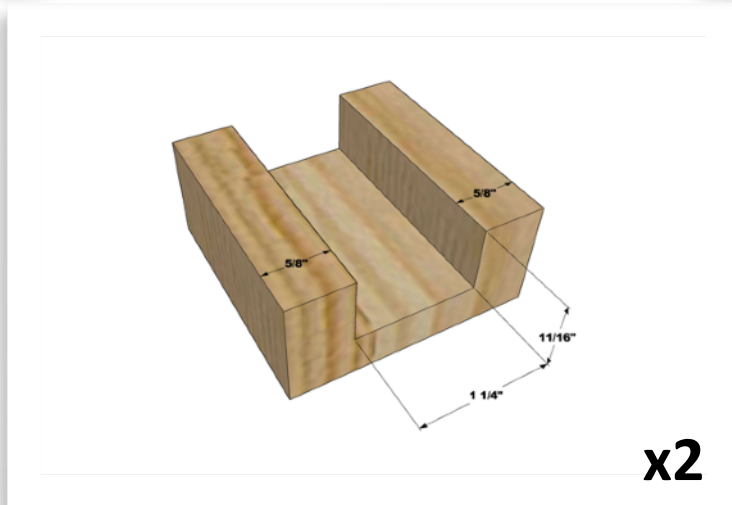
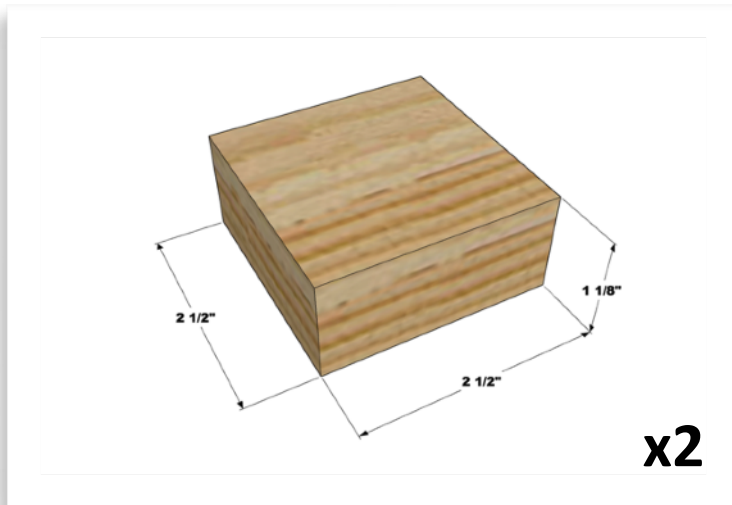

- Cut two pieces 2 1/2" x 2 1/2" and 1 1/8" thick for the Square Nut Brackets.
- Cut a 1 1/4" groove, 11/16" deep in the center of these pieces. Pay attention to the grain direction as shown.

# Square Nut Brackets (continued)

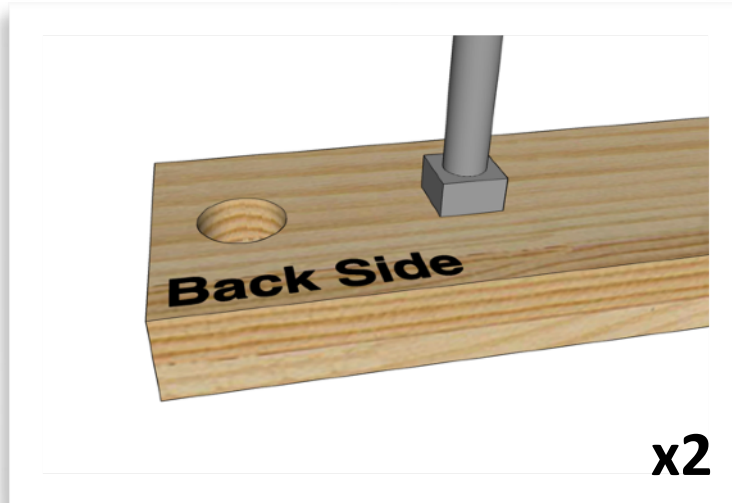
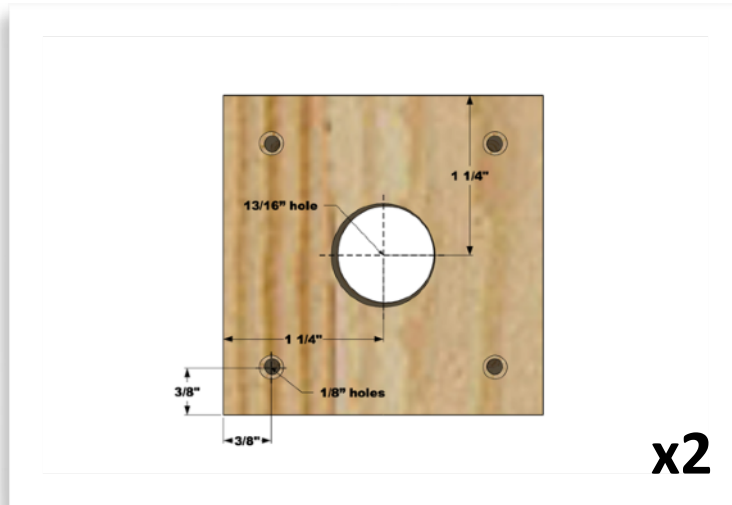

- On the opposite side of the Square Nut Brackets, drill four small holes near the corners with countersinks to allow the screw heads to sit flush with the surface.
- Drill a  $1\frac{3}{16}$ " hole directly in the center of each of the Square Nut Brackets. Do not chamfer this hole.
- From the Hardware Kit, screw the Square Nut onto the Threaded Bar about  $1\frac{1}{2}$ " from one end.
- Place the Rear Jaw, face down, and place the Threaded bar into the smaller hole on the Rear Jaw.

# Square Nut Brackets (continued)

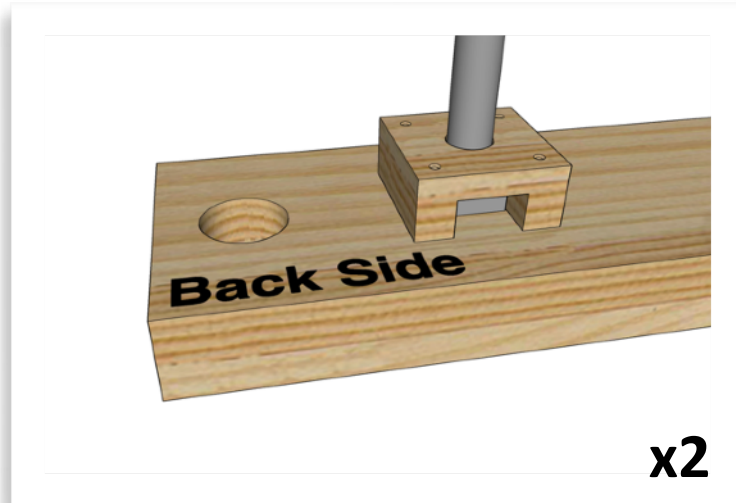

- Put a small dab of glue on the underside of both sides of the Square Nut Brackets as shown.
- Carefully place the Square Nut Brackets over the Threaded Rods and Square Nuts as shown. Center the the hole in the brackets over the Threaded Rods to prevent any binding. Square the brackets to the edges of the Rear Jaw. Make sure the Square Nuts are free to move just a tiny bit within the slot in the Square Nut Brackets. Apply moderate downward pressure on the bracket for a few seconds until it is held in place by suction and then let dry for two hours.
- After the glue has dried, then drive four 2" screws through the Square Nut Brackets into the back side of the Rear Jaw.

# Front Jaw



- Cut one piece 5 3/8" x 24" of 1 1/2" thick wood for the Front Jaw.

*Note: By design, the Front Jaw is 3/8" wider than the Rear Jaw. When assembled, this will create a 3/8" lip on the bottom edge of the jaw, making it much easier to align the vise with the edge of your bench.*

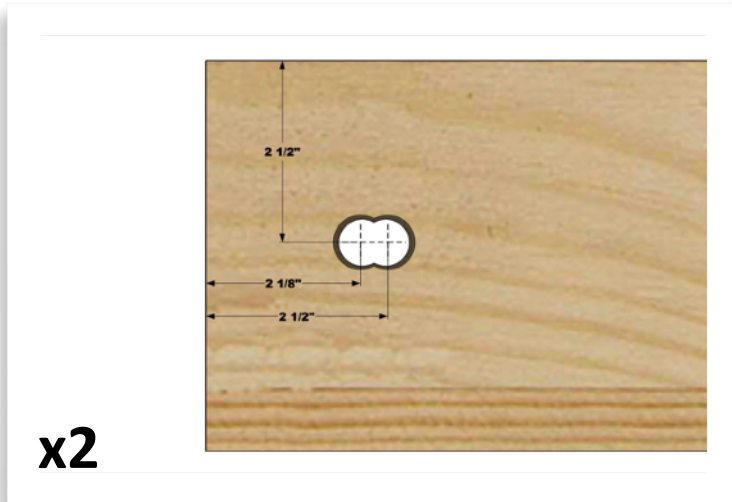

- Make marks to drill two overlapping holes 3/8" apart on both sides of the Front Jaw: one 2 1/8" and the other 2 1/2" from each side, both 2 1/2" from the top as shown here.
- Drill two 3/4" holes at these two marks.

## Front Jaw (continued)



- Chisel or file the intersection of the two  $\frac{3}{4}$ " holes smooth to remove the “widow’s peak” as shown.
- Do the same at the other end.

*Note: This will create elongated slots that will allow the Front Jaw to pivot and clamp tapered parts.*



- Chamfer the top-front edge of the Front Jaw about 1" back.

Leave some flat “meat” on the top edge.

# Assembly & Use



- Place the Square Nut inside the Square Nut Bracket and thread the Threaded Rod into the nut from the front of the Rear Jaw. Do this on both ends.
- Place the Front Jaw onto the Threaded Rod.
- Put the Washers in place.



## Assembly & Use (continued)



- Thread the Knobs from the Hardware Kit onto the end of the Threaded Rod. Use permanent thread locker to keep the knobs from coming off.

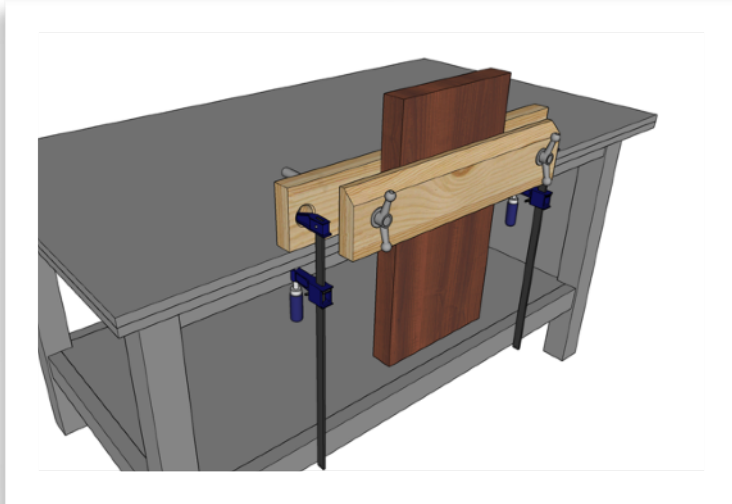

To use the Moxon Vise, clamp the Rear Jaw to your workbench's front edge with two F-style clamps.

You can now move the front Jaw in and out using the knobs.

# Finished!

And with that, you are finished!

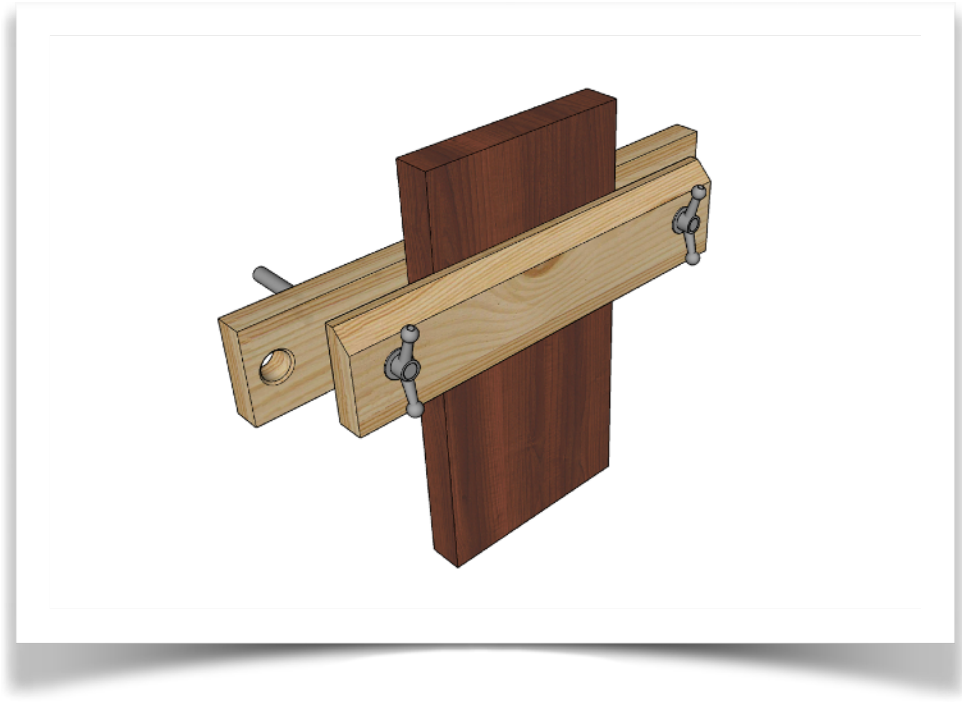

If you have any questions, please reach out via email at [support@taytools.com](mailto:support@taytools.com)

These plans were created for Taylor Toolworks by:



[Instagram](#)



[Facebook](#)

[plans@h2woodshop.com](mailto:plans@h2woodshop.com)